



ALPHA Series

ALPHA Marine Engines

20, 30, 40, 55 Turbo

*Variable speed; maximum power at flywheel at 3000 r/min:
14.9–41.0 kW; 20-55 bhp*

Durable, economical water-cooled marine diesel engines

Suitable for:

- ✓ small offshore boats and work boats
- ✓ pleasure boats and hire fleets
- ✓ propulsion or auxiliary applications

Basic Engine Characteristics

- 2, 3 or 4 cylinders
- raw water heat-exchanger cooling
- direct or indirect injection
- naturally aspirated or turbocharged
- durable, economical and reliable
- low fuel consumption
- long service periods

Design Features and Equipment

- heat exchanger
- water cooled exhaust manifold
- raw water pump
- Fuel filter/agglomerator
- self-bleed fuel system with fuel lift pump
- individual fuel injection pump for each cylinder
- high level oil filler and dipstick
- raw water cooling system pump
- operators' handbook



- high output alternator
- wiring loom
- protection systems
- anti-vibration mountings
- sump lubricating oil drain pump
- paint colour

Optional Items

A range of options enables your engine to be built to your exact needs:

- 12 volt starter motor (insulated earth return)
- 55 amp alternator
- range of gearboxes
- choice of air cleaners
- high-level bearers
- start panels
- drive adaptors

Technical Data					
		20	30	40	55 T
Cylinders		2	3	4	4
Bore	mm	86	86	86	86
Stroke	mm	80	80	80	80
Total cylinder capacity	cm ³	930	1395	1860	1860
Off load idle speed	r/min	900	900	900	900
Fuel consumption (approx) at 2000 r/min	litre/hr	2.5	3.8	5.0	7.1
Oil sump capacity	litre	3.3	4.5	5.6	5.6
Max. installation angle (gearbox down)		20°	20°	20°	20°
Propeller rotation viewed from stern in forward gear		Clockwise			

ALPHA Series: Marine Engines Technical Data Sheet

Dimensions¹ and Weight

Dimension (mm)	20	30	40	55 T
Length A	732	869	969	922
Length B	377	477	577	577
Length C	180	217	217	217
Width D	490	490	490	565
Height E	607	607	607	605

Dry Weight (kg)	150	180	210	230

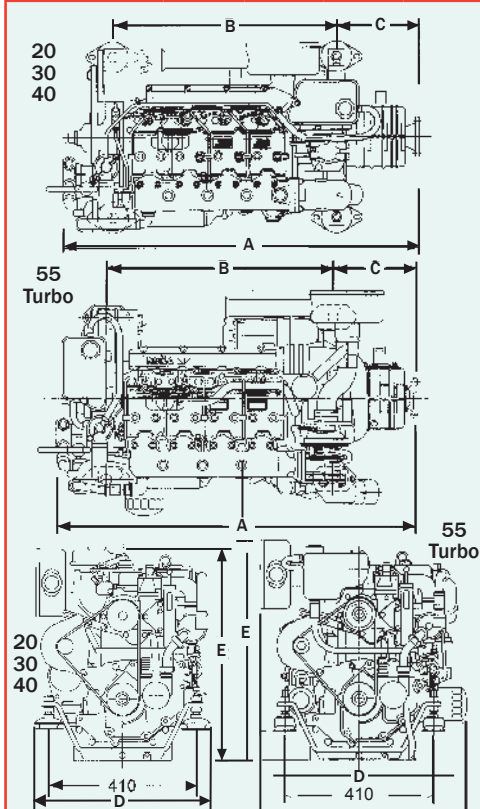

Torque

Model	20	30	40	55
r/min	1800	1800	1800	2000
Nm	53	80	106	155

Distributor's Address

Blank area for distributor's address.

Lister Petter have made efforts to ensure that the information in this data sheet is accurate but reserve the right to amend specifications and information without notice and without obligation or liability.

1. The dimensions (mm) given are for guidance only and must not be used for installation purposes.
 2. Powers, measured at flywheel, are for variable speed builds. Fixed speed builds also available.

Power² Outputs

Injection D=direct I=indirect		D	I	D	I	D	I	D	I	D	I	
Model	Power	r/min	1500	1800	2000	2500	3000					
20	Continuous	kW	6.8	7.4	8.5	9.1	9.6	10.1	11.8	12.2	13.4	13.4
		bhp	9.1	9.9	11.4	12.2	12.9	13.5	15.8	16.3	18.0	18.0
	Intermittent (Fuel Stop)	kW	7.5	8.1	9.4	10.0	10.6	11.1	13.0	13.4	14.7	14.7
		bhp	10.0	10.9	12.6	13.4	14.2	14.9	17.4	18.0	19.7	19.7
30	Continuous	kW	10.3	11.1	12.8	13.6	14.5	15.2	17.7	18.3	20.1	20.1
		bhp	13.8	14.9	17.2	18.2	19.4	20.4	23.7	24.5	27.0	26.9
	Intermittent (Fuel Stop)	kW	11.3	12.2	14.1	15.0	15.9	16.7	19.5	20.1	22.1	22.1
		bhp	15.1	16.4	18.9	20.1	21.3	22.3	26.1	26.9	29.6	29.6
40	Continuous	kW	13.6	14.7	17.0	18.2	19.3	20.2	23.6	24.4	26.8	26.8
		bhp	18.2	19.7	22.7	24.4	25.9	27.0	31.6	32.7	35.9	35.9
	Intermittent (Fuel Stop)	kW	15.0	16.2	18.7	20.0	21.2	22.2	26.0	26.8	29.5	29.5
		bhp	20.1	21.7	25.1	26.8	28.4	30.0	34.8	35.9	39.5	39.5
55 Turbo	Continuous	kW	20.7		26.4		28.7		34.3		37.5	
		bhp	27.7		35.3		38.5		46.0		50.2	
	Intermittent (Fuel Stop)	kW	22.3		28.5		31.0		36.7		40.2	
		bhp	29.9		38.2		41.5		49.1		53.9	

Rating Definitions, to ISO 3046

ISO Standard Conditions
 Barometric pressure 100 kPa
 Relative humidity 30%
 Ambient temperature at air inlet manifold 25°C

1. Fixed speed power: continuous power (ICN)
 The power in kW which the engine is capable of delivering continuously at the stated crankshaft speed, under ISO standard conditions, measured at the flywheel without power-absorbing accessories, provided that the engine is overhauled and maintained in good operating condition and that fuel to BS EN 590 Class A1 or A2, and lubricating oils to the correct performance specification and viscosity classification as recommended by Lister Petter Limited, are used.

2. Fixed speed power: overload power (ICXN)
 The maximum power in kW which the engine is capable of delivering intermittently at the stated crankshaft speed for a period not exceeding one hour in any period of twelve hours' continuous running, immediately after working at the continuous power, under ISO standard conditions and with the provisions specified in (1) above.

3. Variable speed: fuel-stop power, continuous power (IFN)
 The maximum power in kW which an engine is capable of delivering continuously at stated crankshaft speed, under ISO standard conditions and with the provisions specified in (1) above, with the fuel limited so that the fuel stop power cannot be exceeded.

4. Variable speed: fuel-stop power, intermittent power (IOFN)
 The maximum power in kW which an engine is capable of delivering intermittently at the stated crankshaft speed, for a period not exceeding one hour in any period of twelve hours' continuous running, with the fuel limited so that the fuel stop power cannot be exceeded, immediately after running at the rating in (3) above, under ISO standard conditions and with the provisions specified in (1) above.

5. De-rating
 For non-standard site conditions, reference should be made to relevant BS, ISO and DIN standards. The overload capability applies to a fully run-in engine. This is normally attained after a running period of about 50 hours.

 Compliant with EU Stage 3A emissions regulations.  Compliant with EU Stage 3A and USA EPA Interim Tier 4 legislation.



UK

Lister Petter Limited, Dursley, Gloucestershire
 GL11 4HS England
 Tel: +44 (0)1453 544141; fax: +44 (0)1453 546732
 E-mail: sales@lister-petter.co.uk http://www.lister-petter.co.uk