



DELTA Series LLD Water-Cooled Genset

LLD 410

50 Hz; 1500 r/min; power outputs: 33 kVA
60 Hz; 1800 r/min; power outputs: 39 kVA

Water-cooled mounted genset with electronic control module

Choice of:

- ✓ 50 Hz, 1500 r/min or 60 Hz, 1800 r/min
- ✓ Lister Petter DELTA Series water-cooled engine
- ✓ open set (LLD 410) or acoustic set (LLD 410A)

Standard Features

- control system with electronic digital control module (for features see page 3)
- single-bearing, 4-pole brushless alternator
- 95-litre integral fuel tank with contents gauge
- black steel base-plate
- anti-vibration mountings
- 12 V starter battery and leads
- mechanical governing
- output circuit breaker
- emergency stop button (lock-down type)
- high engine temperature and low oil pressure shutdown system
- pusher fan
- Operators' Handbook
- electrical diagram

Open Sets Only:

- engine-mounted exhaust silencer

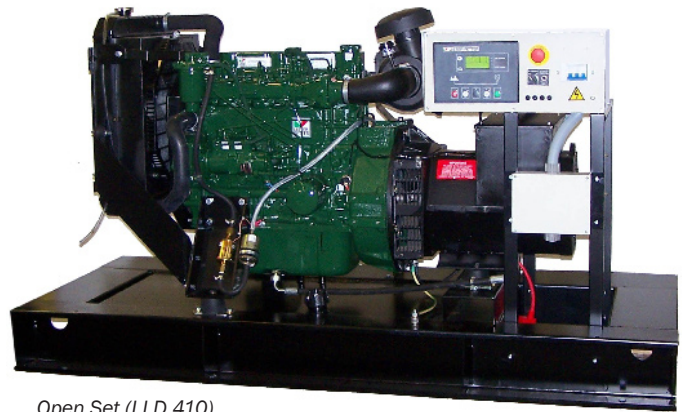

Open Set (LLD 410)

Acoustic Sets Only:

- acoustic canopy
- residential exhaust silencer
- external emergency stop button



Acoustic Set (LLD 410A)

LLD (DELTA) Water-Cooled Genset Technical Data Sheet

Power Outputs				
50 Hz 1500 r/min				
			Three-Phase ¹	
Model	Engine	Rating	kVA	kW
LLD 410 LLD 410A	DWS4	Prime	30.0	24.0
		Standby	33.0	26.4
Voltages available: three-phase 380/220, 400/230, 415/240. ²				
60 Hz 1800 r/min				
			Three-phase ¹	
Model	Engine	Rating	kVA	kW
LLD 410 LLD 410A	DWS4	Prime	36.0	28.8
		Standby	39.6	31.7
Voltages available: three-phase 220/127, 230/133. ²				

1. **Power Factor:** Three-phase, 0.8 pf. Single-phase versions available on request.

2. **Voltages available:** Other voltages are available on request.

Power outputs are based on the optimum make of alternator for the set.

Rating Definitions to ISO 8528-1

All ratings are in accordance with ISO 8528-1.

Rating Conditions

A standard generating set is designed to operate in environmental reference conditions of 25 °C, 100 kPa and 30% humidity.

Prime Power

This rating is for the supply of continuous electrical power (at variable load). There is no limit on the annual hours of operation and 10% overload power can be supplied for 1 hour in 12.

Standby Power

This rating is for the supply of continuous electrical power (at variable load) in the event of a utility power failure. No overload is permitted.

Optional Items:

- residential exhaust silencer for open sets (as fitted to acoustic sets)
- 2-wheel trailer
- basic tool kit

Engine Specification

- Lister Petter DELTA Series diesel engine
- water-cooled
- indirect injection
- naturally aspirated
- four cylinders
- medium-duty cyclonic air cleaner
- oil and fuel filters
- fuel-lift pump
- 12 V electric starting system with battery-charge alternator

Alternator Specification

- single-bearing, 4-pole brushless alternator
- solid state AVR with $\pm 1.5\%$ voltage regulation as standard
- class "H" insulation on the rotor and stator, IP23 protection class

Approximate Fuel Consumption				
			Litres/Hour	
			50 Hz	60 Hz
Model	Engine	Load	1500 Tr/mn	1800 Tr/mn
LLD (410A)	DWS4	100%	8.6	10.3
		75%	6.3	7.4

Sound Pressure Levels (dBA) ²	
50 Hz, 1500 r/min	
Acoustic genset	dBA at 75% load, 7m
LLD 410A	70

2. Noise levels are in accordance with European Noise Directive 2001/14/EC.

Control System Features

Control Cubicle

All LLD and LLDA sets have a control cubicle mounted on a vibration-isolated support, which has the following features:

- electronic digital control module with monitoring/control facility and warning indicators
- automatic shutdown protection
- emergency stop button (lock-down type)
- AC output circuit breaker with over-current protection
- DC circuit control switch and overload circuit breaker

The control module gives digital readouts of:

- generator voltage (phase-to-phase and phase-to-neutral)
- generator current (each phase displayed separately)
- output frequency
- engine speed
- engine oil pressure
- engine coolant temperature
- battery voltage
- engine hours run

The control module has indicators for:

- overspeed/underspeed
- emergency stop
- engine oil pressure
- engine temperature
- failure to start
- battery charger failure

Automatic shutdown occurs under:

- low engine oil pressure
- high engine temperature
- overspeed/underspeed
- failure to start after three attempts

Manual/Remote Start Sets

These sets have the flexibility of either manual or remote automatic operation:

- manual operation is by **START** and **STOP** push-buttons on the control module
- remote operation is achieved by connecting a 2-wire circuit to the relevant terminals on the control module and is activated by setting the control module to **AUTO**

Automatic Mains Failure Sets (AMF)

In the event of a mains failure, the generating set will automatically operate to supply the electrical load. In addition to the standard features, automatic mains failure sets have:

- wall-mounted cubicle governing automatic mains failure operation
- control module timer circuits set to delay start, delay transfer back to mains and delay stop to allow for engine cooldown
- solid-state automatic battery charger that maintains charge when set is not running

The wall-mounted cubicle features:

- mains monitoring unit to control set operation
- load-transfer contactors, mechanically and electrically interlocked (rated for set output)
- indicator for mains-on-load or plant-on-load

LLD (DELTA) Water-Cooled Genset Technical Data Sheet

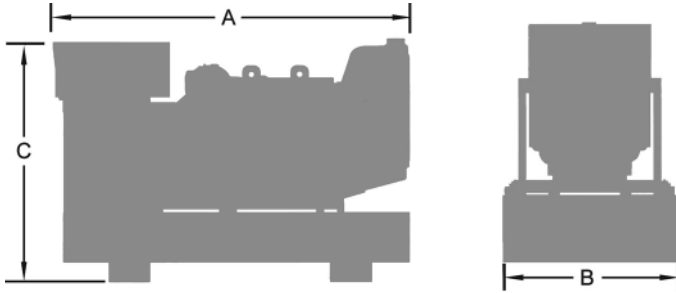
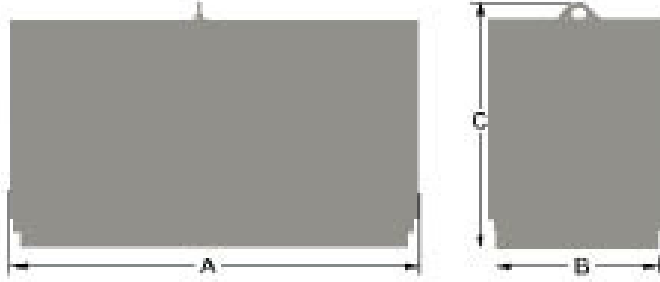
Approximate Dimensions			
	Open set LLD 410		
	Dry Weight	kg	592
		lb	1305
	Length (A)	mm	1600
		in	63
	Width (B)	mm	700
in		27.5	
Height (C)	mm	1110	
	in	44	
	Acoustic set LLD 410A		
	Dry Weight	kg	820
		lb	1808
	Length (A)	mm	2000
		in	79
	Width (B)	mm	850
in		33.5	
Height (C)	mm	1300	
	in	51	

A comprehensive range of options allows you to select a specification that matches your requirements. Please ask your Lister Petter distributor. (See panel below left.)

Distributor's Address

Lister Petter have made efforts to ensure that the information in this data sheet is accurate but reserve the right to amend specifications and information without notice and without obligation or liability.



UK

Lister Petter Limited, Dursley, Gloucestershire
 GL11 4HS England; Tel: +44 (0)1453 544141;
 Fax: +44 (0)1453 546732;

E-mail: sales@lister-petter.co.uk <http://www.lister-petter.co.uk>