



T Series TR Marine Engines

TR2, TR3 Marine

Maximum power output: 25 kW; 34 bhp
Speed range: 1500–2500 r/min

Air-cooled marine diesel engines for leisure and commercial craft

Suitable for:

- ✓ work boats
- ✓ pleasure boats
- ✓ propulsion and auxiliary applications

Basic Engine Characteristics

- 2 or 3 cylinders
- air cooled
- direct injection
- naturally aspirated
- durable, economical and reliable
- low fuel consumption and long service periods

Design Features and Equipment

- integral flywheel fan air cooling
- electric or hand start (see options)
- engine-mounted air cleaner
- fuel filter/agglomerator
- fuel lift pump and steel fuel lines
- high level dipstick
- operators' handbook

Optional Items

The range of options to enable your TR marine engine to be built to your exact needs includes:

- 12-volt starter motor (insulated earth return design) and 55 Amp marine alternator
- raised hand starting at gear end
- sump drain pump
- engine bearers
- range of gearboxes
- vibration isolating engine mounts
- hot air outlet duct adaptor
- flexible coupling disc
- panel with warning lights, alarms and keyswitch
- engine wiring
- Morse type fittings



Warranty

- standard: two years from delivery
 - optional five-year limited warranty
- Conditions apply.

Technical Data			
		TR2 Marine	TR3 Marine
Cylinders		2	3
Bore x Stroke	mm	98.4 x 101.6	
Total cylinder capacity	cm ³	1550	2320
Maximum power at flywheel at 2500 r/min (continuous)	bhp	23.2	34.7
Max. torque at flywheel (with engine at 2500 r/min)	Nm	72.6	108.9
Off load idle speed	r/min	850	850
Fuel consumption (approx) at 75% load, 2000 r/min	litre/hr	3.2	4.7
Oil sump capacity	litre	4	6
Net weight (dry)	kg	185	230
Max. installation angle (gearbox down)		15°	15°
Propeller rotation (viewed from the stern in forward gear)		Clockwise	

T Series: TR Marine Engines Technical Data Sheet

Dimensions ¹		
	TR2 Marine	TR3 Marine
A	897	1024
B	548	675
C	158	170
D	23	33

The illustrations show the raised hand start which is an optional accessory.

D is the distance of gearbox output centre line below the underside of the engine mounts.

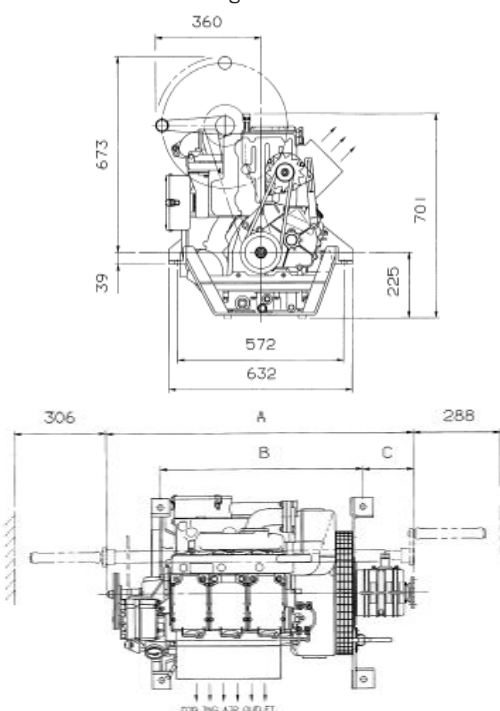

Notes:

- The dimensions (mm) given are for guidance only and must not be used for installation purposes.
- Power ratings (measured at the flywheel) and fuel consumptions, apply to a fully run-in, non-derated engine without power absorbing accessories or transmission equipment.
- The overload capability applies to a fully run-in engine. This is normally attained after a running period of about 50 hours.
- For fixed speed engines the powers at these speeds are the same.

Distributor's Address

Lister Petter have made efforts to ensure that the information in this data sheet is accurate but reserve the right to amend specifications and information without notice and without obligation or liability.

Power Outputs ² to ISO 3046						
Variable Speed		r/min	1500 ⁴	1800 ⁴	2000	2500
TR2	Continuous Power	kW	11.0	13.1	14.5	17.3
		bhp	14.8	17.6	19.4	23.2
	Intermittent Power ³	kW	12.1	14.4	16.0	19.0
		bhp	16.2	19.3	21.5	25.5
TR3	Continuous Power	kW	16.8	20.2	22.2	25.9
		bhp	22.5	27.1	29.8	34.7
	Intermittent Power ³	kW	18.5	22.2	24.4	28.5
		bhp	24.8	29.8	32.7	38.2

Torque to ISO 3046						
Variable Speed		r/min	1500	1800	2000	2500
TR2	Intermittent Power ³	Nm	77.0	76.4	76.4	72.6
TR3		Nm	117.8	117.8	116.5	108.9

Rating Definitions, to ISO 3046

ISO Standard Conditions

Barometric pressure 100 kPa
 Relative humidity.....30%
 Ambient temperature at air inlet manifold 25°C

1. Fixed speed power: continuous power (ICN)

The power in kW which the engine is capable of delivering continuously at the stated crankshaft speed, under ISO standard conditions, measured at the flywheel without power-absorbing accessories, provided that the engine is overhauled and maintained in good operating condition and that fuel to BS EN 590 Class A1 or A2, and lubricating oils to the correct performance specification and viscosity classification as recommended by Lister Petter Limited, are used.

2. Fixed speed power: overload power (ICXN)

The maximum power in kW which the engine is capable of delivering intermittently at the stated crankshaft speed for a period not exceeding one hour in any period of twelve hours' continuous running, immediately after working at the continuous power, under ISO standard conditions and with the provisions specified in (1) above.

3. Variable speed: fuel-stop power, continuous power (IFN)

The maximum power in kW which an engine is capable of delivering continuously at stated crankshaft speed, under ISO standard conditions and with the provisions specified in (1) above, with the fuel limited so that the fuel stop power cannot be exceeded.

4. Variable speed: fuel-stop power, intermittent power (IOFN)

The maximum power in kW which an engine is capable of delivering intermittently at the stated crankshaft speed, for a period not exceeding one hour in any period of twelve hours' continuous running, with the fuel limited so that the fuel stop power cannot be exceeded, immediately after running at the rating in (3) above, under ISO standard conditions and with the provisions specified in (1) above.

5. De-rating

For non-standard site conditions, reference should be made to relevant BS, ISO and DIN standards. The overload capability applies to a fully run-in engine. This is normally attained after a running period of about 50 hours.



UK

Lister Petter Limited, Dursley, Gloucestershire
 GL11 4HS England

Tel: +44 (0)1453 544141; fax: +44 (0)1453 546732

E-mail: sales@lister-petter.co.uk <http://www.lister-petter.co.uk>